

# Sunfung Technology Corporation Ltd

Leading Print Finishing Equipments Supplier



Sunfung Technology Corporation Ltd

Leading Print Finishing Equipments Supplier



# Sunfung Technology Corporation Ltd

Leading Print Finishing Equipments Supplier

## CONTENTS

Paper Folder

Paper Cutter

Card Cutter

Laminator

Creaser

Label Cutter

## ABOUT US

Sunfung is a manufacturer and supplier for paper folder, paper cutter, card cutter, laminator, creaser and label cutter from China.

Our R&D team been in the market working for Duplo China over 8 years.

6 years experiences in the market, most products have CE certification, passed SGS inspection according customers request.

Sunfung hold the philosophy to make your each order with stable quality with less trouble happens. Reducing your time and energy for service is helping you save money, increase margins.

We do not guarantee offer you best price, but offer best value products for long-term business cooperation.

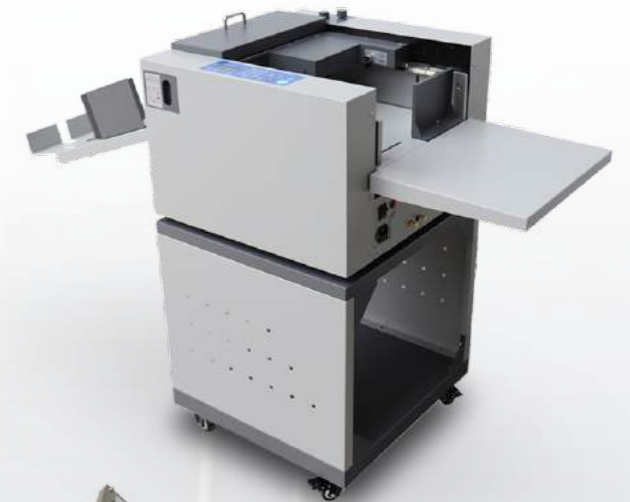



## SF-12M

Entry level A4 paper folder

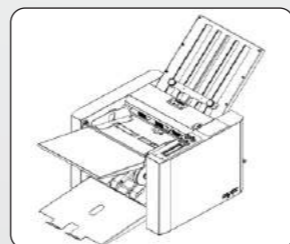
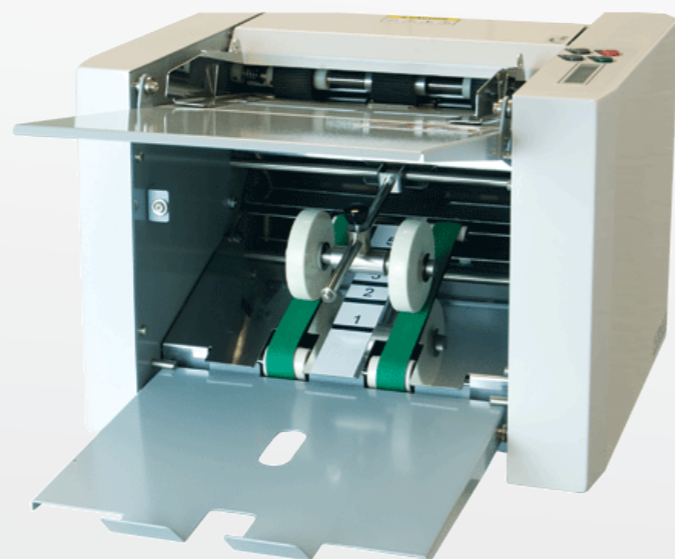

### MAIN FEATURES:

Folding speed:	7000 sheets/ hour
Paper size:	B6(125x176mm) - A4(210x297mm)
Paper weights:	35~120 g/m <sup>2</sup>
Hopper capacity:	300 sheets, 64 g/m <sup>2</sup>
Power supply:	220V, 50Hz/ 110V, 60Hz
Dimensions:	W 490 x D 480 x H 390 mm
Weight:	19Kg

### PRODUCT FEATURES:

Digital display with ascending and descending counter, guarantee an easy operation. Cleared marked fold settings. Include Single, Letter, Zigzag, Double parallel. Extendable feed tray saving your space on the desk.

Paper folder SF-12M is solid and durable machine, which is an extremely economical solution to fold higher volumes of paper as well. The SF-12M can process a large variety of applications. The SF-12M Office Desktop Folder provides an economical solution for low-volume folding projects.

User-friendly features include an LCD control panel with 3-digital resettable counter, Auto Batch for processing sets of documents, and an output conveyor with easily-adjustable stacker wheels for neat sequential stacking of folded pieces.

Clearly marked fold settings and out-of-the-box operation make this folder ideal for churches, schools and small office that demand quick and easy set-up with minimal adjustment.

Clearly marked fold settings and out-of-the-box operation make this folder ideal for churches, schools and small office that demand quick and easy set-up with minimal adjustment.

## SF-14M

Compact paper folder with 4 fold plates

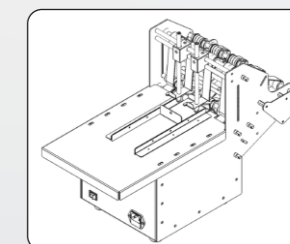
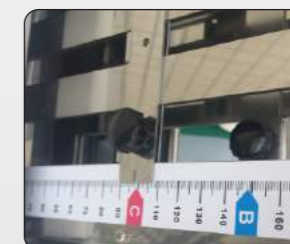

### MAIN FEATURES:

Folding speed:	7000 sheets/ hour
Paper size:	B6(125x176mm) - A4(210x297mm)
Paper weights:	35~120 g/m <sup>2</sup>
Hopper capacity:	300 sheets, 64 g/m <sup>2</sup>
Power supply:	220V, 50Hz/ 110V, 60Hz
Dimensions:	W 530 x D 480 x H 480 mm
Weight:	25Kg

### PRODUCT FEATURES:

Connect with A4 vertical stacker to collect small folded sheets. More than 10 fold types available, minimum folded sheet height 17 mm. Extendable feed tray saving your space in your room.

Paper Folder SF-14M is a fast, dependable and easy-to-use solution for virtually all folding applications. Popular folds are clearly marked on the fold plates for quick set-up and operation, simply slide the fold stop to the desired fold and go. Additional fold adjustments can be made with the fine tuning knobs at the end of each fold plates for precision folding.

It's durable construction, simple operation, excellent design and attractive appearance make it a unique machine for the pharmaceutical industry.

Paper folders are useful in almost every industry. For the pharmaceutical industry, Sunfung made the SF-14M. With simple operation and multi-function purpose, the SF-14M paper folder provides convenience and efficiency.



# SF-32M

## A3 Efficient Paper Folder

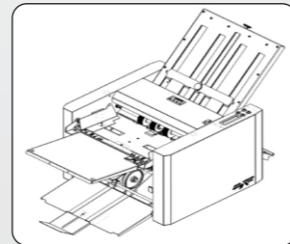
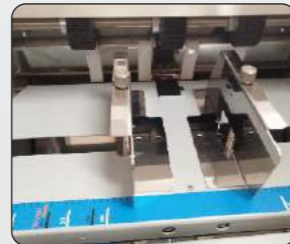

### MAIN FEATURES:

Folding speed:	7000 sheets/ hour
Paper weights:	50~200 g/m <sup>2</sup>
Paper size:	B6(125x176mm) – A3(297x420mm)
Hopper capacity:	500 sheets, 64 g/m <sup>2</sup>
Power supply:	220V, 50Hz/ 110V, 60Hz
Dimensions:	W 670 x D 640 x H 510 mm
Weight:	35Kg

### PRODUCT FEATURES:

Three feed rollers avoid slip, adjustable feeding pressure.  
500 sheets hopper capacity for A3 papers  
Paper delivery roller for better paper collection

Paper Folder SF-32M is solid and durable machine, which is an extremely economical solution to fold higher volumes paper. It can process a large variety of applications and easy to operate. It works fast and accurately and can be used in any office and mailrooms.  
The SF-32M Desktop Paper Folder is able to handle sheets up to A3. The adjustment of the folding plates is done in no time: both folding plates have a self-explaining scale for 6 different fold types. Each plates is equipment with a quick and fine-tune adjustment to achieve perfect folding result. Whether the application is a letter, flyer, brochure or billing statement etc.

# SF-34M

## Powerful A3 Paper Folder with 4 Fold Plates

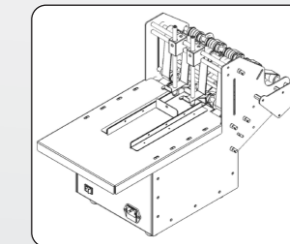
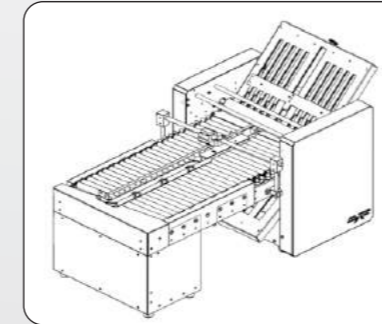
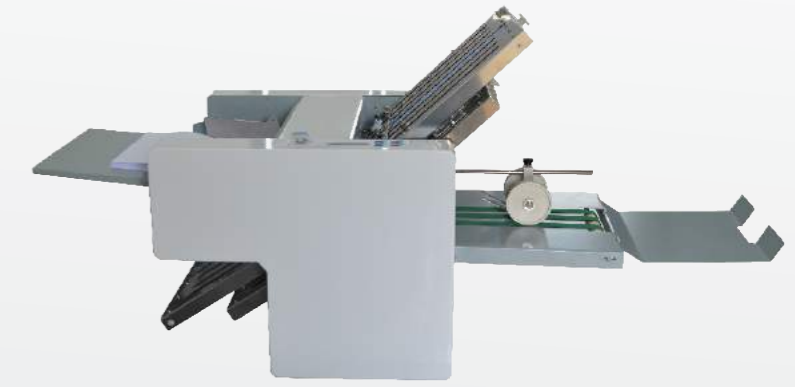

### MAIN FEATURES:

Folding speed:	7000 sheets/ hour
Paper size:	B6(125x176mm) – A3(297x420mm)
Paper weights:	50~200 g/m <sup>2</sup>
Hopper capacity:	500 sheets, 64 g/m <sup>2</sup>
Power supply:	220V, 50Hz/ 110V, 60Hz
Dimensions:	W 900 x D 580 x H 520 mm
Weight:	55Kg

### PRODUCT FEATURES:

Over 10 fold types available based on 4 fold plates.  
Adjustable feeding pressure for different paper thickness, avoid slip.  
Connect with 2P/4P for cross folding lines, collecting small folded sheets 23 mm with A3 vertical stacker.

Paper Folder SF-34M is a fast, dependable and easy-to –use solution for virtually all folding applications. Fold adjustments can be made with fine tuning knobs at the end of each fold plates for precision folding.  
The SF-34M paper folder handles the paper with a max speed 7,400 sheets/h. The capacity of the automatic feed station is up to 500 sheets.  
For the Pharmaceutical, Beauty Industry SF-34M paper folder is a multi-purpose functioning folding machine for the pharmaceutical, cosmetic, toy factory. It's durable construction, simple operation, excellent design make it a unique in the world for the pharmaceutical industry etc.



# SF34M + 2P+A3 Stacker

A3 Size Tabletop Cross Fold Line in China

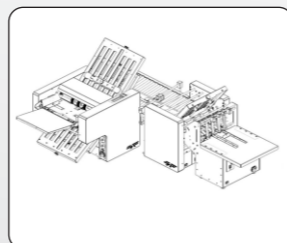
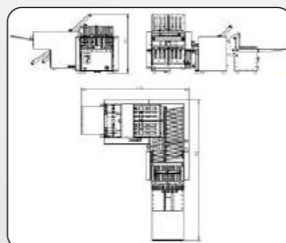
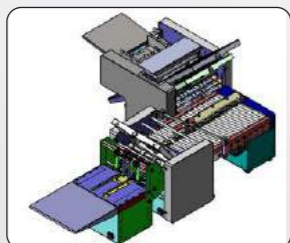

## MAIN FEATURES:

Folding speed:	7000sheets/ hour
Paper size:	B6(125x176mm) – A3(297x420mm)
Paper weights:	50~157 g/m <sup>2</sup>
Paper stack capacity:	500 sheets, 80 g/m <sup>2</sup>
Power supply:	220V, 50Hz/ 110V, 60Hz
Dimensions:	W 1425 x D 1362 x H 635 mm
Weight:	98Kg

## PRODUCT FEATURES:

It's FIRST tabletop cross folding line in China. This cross folding line handles the paper with a maximum speed 7,400 sheets/h. The capacity of the automatic feed is up to 500 sheets.

Over 20 fold types include cross folding available. It's one stop for all folding needs of the digital printing papers. The cross folding line is very famous for toy factories, pharmacy factories, and some other small digital printing shops, which need to do cross paper folding. Minimum can collect 23mm folded sheet size when we add the A3 stacker according customer demands. That makes it more popular in printing or packaging market.

# SF-490E Electric Paper Cutter

Compact powerful electric paper cutter

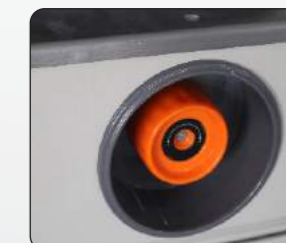
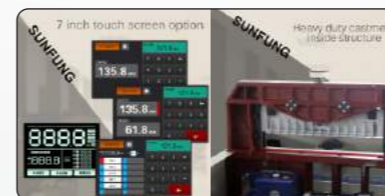

## MAIN FEATURES:

Model:	SF-490E	SF-460E
Max width (mm):	490	460
Min depth (mm):	30	30
Cut height:	80	80
Accuracy (mm):	0.3	0.3
Back gauge control:	Electric	Electric
Display:	Touch screen	Touch screen
Program:	5 cuts x 99 programs	5 cuts x 99 programs
Safety protection:	IR Beam guard	IR Beam guard
Power supply:	220V,50Hz/60Hz	220V,50Hz/60Hz
Dimensions(mm):	950X780X1225	945x725x1310
Net weight(kg):	165	150

## PRODUCT FEATURES:

- Accommodate 490mm cutting width
- Easy to read LCD display
- Full light beam curtain and two cut buttons for operator safety
- LED illuminated cutting line
- 99 programs with 5 cuts each
- Power backgauge, variable speed backgauge move

Sunfung offer quality electric Paper Cutter machines that are durable and precise. Paper cutter can be used in quick print, copy shop, or on-demand market. Even for low volume cutting environment like offices. SF-490E automatic paper cutter offers precision cutting for paper stacks up to 80mm, 490mm width max. 5 cuts per program with 99 programs totally. IR safety beam guard. Electric clamp and electric backgauge control. 0.3mm cutting accuracy with quiet operations.



## SF-P paper cutter

Productive hydraulic Paper Cutter

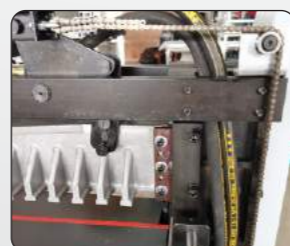

## SF-H Paper Cutter

Heavy duty guillotine Cutter with 10 inch Screen

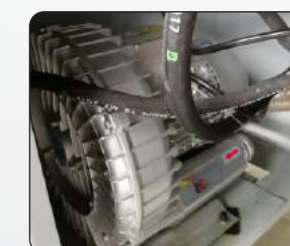

### MAIN FEATURES:

Model:	SF-52P	SF-67P	SF-72P
Max width (mm):	520	670	720
Min depth (mm):	30	30	30
Max Cut height(mm):	80	80	80
Accuracy (mm):	0.2	0.2	0.2
Paper clamp:	Hydraulic+Foot pedal	Hydraulic+Foot pedal	Hydraulic+Foot pedal
Back gauge control:	Programmable	Programmable	Programmable
Display:	LED touch screen	LED touch screen	LED touch screen
Safety:	Blade lock+CE safety beam	Blade lock+CE safety beam	Blade lock+CE safety beam
Power supply:	220V, 50Hz/60Hz	220V, 50Hz/60Hz	220V, 50Hz/60Hz
Dimensions:	W1410XD1140XH1520	W1610XD1310XH1520	W1610XD1310XH1520
Net weight(Kg):	350	410	460
Gross weight(Kg):	400	480	550

### PRODUCT FEATURES:

Hydraulic-powered, rugged construction  
10 inch touch screen

Beam with CE standard for operator safety  
Double guide back gauge

The capacity to program up to 100 jobs/16cuts  
Clamp pressure from 200—20,000 N adjustable

PC board with mechanical safety relay  
Aviation aluminum sheet table with hard oxidation treatment

SF-P series hydraulic and programmable paper cutters are available in fully-automatic models. Cutting widths are available up to 720 mm. SF-P has double guide back gauge to promise long time use. SF-P series of paper cutters with US / Europe OEM quality so that they are user friendly and easy to operate, thanks to features such as LED display touch screen with full status and side buttons for easy two-hand operation. PC board with mechanical safety relay satisfied demand of customer and longtime job. It is easy to move paper with aviation aluminum sheet table. SF-P series paper cutter duty cutting – up to 18,000 cuttings after sharpening.

### MAIN FEATURES:

Model:	SF-H52P	SF-H67P	SF-H80P
Max width (mm):	520	670	800
Min depth (mm):	30	30	30
Max Cut height(mm):	80	80	80
Accuracy (mm):	0.2	0.2	0.2
Paper clamp:	Hydraulic+Foot pedal	Hydraulic+Foot pedal	Hydraulic+Foot pedal
Back gauge control:	Programmable	Programmable	Programmable
Display:	LED touch screen	LED touch screen	LED touch screen
Safety:	Blade lock+CE safety beam	Blade lock+CE safety beam	Blade lock+CE safety beam
Power supply:	220V,50Hz/60Hz	220V,50Hz/60Hz	220V,50Hz/60Hz
Dimensions:	W1250XD1010XH1390	W1400XD1035XH146	W1650XD1085XH1460
Net weight(Kg):	450	550	650
Gross weight(Kg):	500	620	730

### PRODUCT FEATURES:

Aviation aluminum sheet table with hard oxidation treatment

PC Board with safety relay and transducer control  
CE standard Beam for operator safety

10 inch touch screen

Double linear guide rail back gauge control  
The capacity to program up to 100 jobs/32cuts  
Clamp pressure from 200—20,000 N adjustable  
AC Servo Motor and Taiwan

Vane pump

Air Table

Quiet cutting

SF-H series paper cutter is new heavy duty guillotine cutters from Sunfung. There are the most powerful to precisely cut large stacks of paper stock. Cutting widths are available up to 800 mm.

SF-H series paper cutters satisfied normal need with program up to 100 jobs/32cuts. It has AC servo Motor and Vane pump from Taiwan promise longtime job and strong quality.

SF-H series paper cutter has 10 inch touch screen full color display help you easy to use. And CE standard beam for operator safety

Our paper cutters are designed to last for years of print shop duty cutting – up to 18,000 cuttings after sharpening.



# SF-390E Laminator

Entry double side Electric Laminator

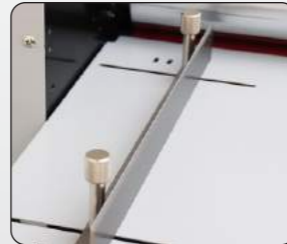

# SF-390A automatic Laminator

Fully Automatic Hydraulic Laminator

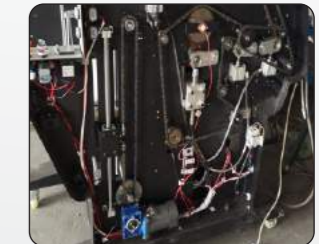
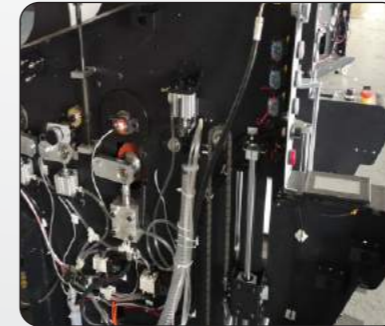

## MAIN FEATURES:

Model:	SF-390E
Max laminate length(mm):	375
Laminate paper(gsm):	80-400
Max speed(Meters/min):	6
Max temperature(degree):	140
Display:	Led Display
Motor:	AC motor
Control system:	Electric
Power:	220V/110V, 50-60Hz
Core size:	1 inch/ 3 inch
Power consumption(W):	1600
Dimension(mm):	W1250 X D680 X H450
Weight(kg):	65
Option:	Stand

## PRODUCT FEATURES:

- Manually feeding
- Double side lamination
- Temperature control separately
- Compact design
- Anti-curl feature
- Non-sticky film roller
- Steel roller for even heating
- Laminated paper collection with perforations

The electric laminator 390E from Sunfung is an entry-level laminator, allows the flexibility of double side OPP roll film lamination and encapsulation providing an affordable and effective solution to outsourcing. Compact-designed laminator helps breathe life into your business by allowing you to provide customers with a service you previously had to outsource, enabling you to offer your customer a true one-stop-shop.

The semi-automatic feed with a perforation tool makes it easy to feed your work through the laminator and separations. Truly affordable semi-auto electric laminator for digital printing market.

## MAIN FEATURES:

Model:	SF-390A
Max film width(mm):	380
Max film thickness(mm):	6
Power consumption(W):	1500
Max speed(meters/min):	7
Temperature range(degree):	20 - 140
Paper thickness(gsm):	90 - 600
Feeding method:	Dual air suction
Feeding capacity:	35cm/ 1800 sheets, 200gsm
Warm up time(min):	10
Pressure control:	Hydraulic
Rollers:	6(1 steel + 5 rubber)
Power supply:	AC 220V-240V,50Hz - 60Hz
Dimension(mm):	W1300 X D750 X H1400
Gross weight(kg):	400

## PRODUCT FEATURES:

- Auto feeding with dual air suction
- Auto separation
- Thermal or Cold lamination
- Digital foiling
- 35 cm feeding capacity, 1800 sheets 200gsm paper
- Automatic roll laminator SF-390A are compact and environmentally-friendly, dual laminator and foil-flaring devices, designed to offer an in-house decorative effects solution for short-run, on demand digital applications, as well as lamination for traditional lithographic offset output too!
- Automatic feeding & Automatic separation help release operators hands, increase their efficiency and save their time. 7-8 meters per min can satisfy most of on demand digital applications. Foil rewinder allow customers to make foiling on digital printings. Heavy duty hydraulic laminator guarantee daily workings in long-term.



## SF-Z hydraulic laminator

Hydraulic laminator with separation feature



### MAIN FEATURES:

Model:	SF-520Z	SF-720Z
Max film width(mm):	480	690
Max film thickness(mm)	6	6
Power consumption(W):	4000	4000
Max speed(m/min) :	12	12
Temperature range( C ):	20-160	20-160
Paper thickness( gsm )	90-600	90-600
Warm up time:	12 minutes	12 minutes
Rollers:	4 ( 2 steel + 2 rubber )	4 ( 2 steel + 2 rubber )
Core size:	3"	3'
Heating method:	Steel roller	Steel Roller
Hydraulic pressure:	5-6 Mpa	5-6 Mpa
Power supply:	220-240, 50-60Hz	220-240, 50-60Hz
Package Dimension(mm):	W900 x D1600 x H1400	W1100 x D1900 x H1400
Gross weight(Kg)	380	480

### PRODUCT FEATURES:

Auto separation feature  
Hydraulic control paper press  
Heavy duty construction  
Fast speed and temperature control  
Non-sticky film roller  
Thermal or Cold laminating  
Steel roller for even heating  
Overlap feed separation  
Higher standard electrical control.

The semi-automatic feed with auto-overlap makes it easy to feed your work through the laminator and the separator ensures it's ready for the guillotine the moment it's been laminated.  
Roll laminators from Sunfung have unique anti-curl technology, in sync with the control panel, ensures that whatever you laminate – a menu, a book cover or a sheet of business cards – comes out flat with no curl or uplift.

## SF-E Business Card Cutter

0.05 Accuracy fast speed cutter



### MAIN FEATURES:

Model:	SF-EA4	SF-EA3
Paper thickness(gsm):	80 - 450	180 - 350
Paper feed size:	A4 size(210x297mm), 8.5"x11",8.5"x14"	A3 size(297x420mm), 11"x17"
Card size:	(85,89,90,95,custom) x (1-600mm) or (45,50,54mm)	
Paper type :	Coated paper, non-coated paper, laminated paper	
Feed volume:	10mm or 40 pcs paper (0.25mm)	
Feeding:	Double roller friction	
Cutting accuracy(mm):	+/-0.05	+/-0.05
Cutting speed:	100 pcs/ 30 seconds	100 pcs/ 30 seconds
Machine dimension(mm):	460x540x260	500x620x260
Weight(Kg):	19	25
Power supply:	AC 90-220V, 50/60Hz, 0.5A	AC 90 - 260V, 50/60Hz, 0.5A

### PRODUCT FEATURES:

40 sheets, 250gsm paper feeding capacity  
Automatic friction feeding  
Programmable set  
Heavy duty slitter blade  
CE safety standard  
Self-sharpening blades  
1 million cutting guarantee

Sunfung introduces print finishing equipment the SF-E series automatic Business Card Cutter. This automatic friction feed business card cutter comes standard with gutter cut producing 10-up business cards from a A4, A3, SRA3, A3+ size sheet. Able to cut coated sheet, laminated sheet, card sheet and other printed material. Equipped with waste bin, easy to use LCD display screen and the ability to control the cutting accuracy with a register mark reader. Additional cartridges are available to produce different card sizes. This high precision machine is built stylish and durable with long life self-sharpening blades. This machine is simple to operate and requires little maintenance. Exchangeable cartridges allows you to cut 2" x 3.5" cards.



# Automatic Creaser SF-20

## Top Suction Feeding

### PRODUCT FEATURES:

- Coated paper, offset paper, laminated paper, photo paper 60-350 gsm
- Top suction feeding
- 32 lines available in one crease
- 3000 sheets per hour creasing speed
- 90mm paper feed tray capacity
- High precision crease position +/-0.2mm
- Slide-in option tools
- Creasing depth and skew adjustment

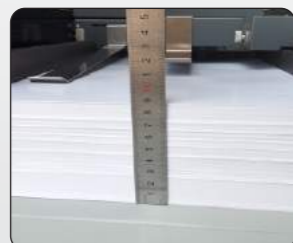

The SF-10 & SF-20 Automatic Creaser is an ideal tabletop creaser for the digital printing and photo album making industry. With creasing, perforating available, it handles coated paper, laminated paper, offset paper, etc. The 3-in-1 machine simply discards the probability of commonly occurring issue of cracking of digitally-printed products. The sheets with fine crease lines can easily pass through paper copiers and printers. This high-performance creaser machines eliminates mundane tasks, thereby emerging as an asset for office and semi-industrial applications.

The SF-20 auto creaser is a versatile automatic creaser with multiple finishing options; perforating, scoring, creasing. Equipped with a 90mm vacuum pile feeder, an easy to use LCD screen and keyboard, skew compensation, and sheet size up to 320 x 660mm. With a maximum of 32 crease/perf positions per sheet, 30 job memory, and speeds up to 3,000 sph, the SF-20 auto creaser is a capable and affordable finishing option.

### MAIN FEATURES:

Model:	SF-10	SF-20
Infeed size(mm):	50*90 - 340*900	150*210 - 320*900
Paper Type:	Chrome, laminated, UV coated,	
Paper weight(gsm):	60-300	60-300
Word accuracy(mm):	+/- 0.2	+/- 0.2
Feed capacity(mm):	/	90
Output capacity(mm):	30	90
Feeding type:	Manual feeding	Top suction feeding
Job memory:	30	30
Power supply:	220V/110V, 50-60Hz	220V/110V, 50-60Hz
Power(W):	160	200
Weight(Kg):	50	68
Package dimensions(mm):	610x600x500	760x680x530
Machine dimensions(mm):	1190x505x405	1640x560x400
Option:	Stand	Stand
Gross weight(Kg)	380	480

# SRA3 sheet to sheet Digital Label Cutter

### PRODUCT FEATURES:

- Auto feeding with hopper capacity up to 100 sheets or 18mm thick
- Variable printable self-adhesive material such as paper, film, nonwoven cloth, etc
- 4 interfaces include U disk, USB, WIFI and LAN network
- Industrial high precision sensor better recognize mark line in different material with various color.
- Quiet label cutting with fast speed to 800mm/s
- 50-800g adjustable downforce, to cut 1mm thick max
- Easy operation and daily maintenance

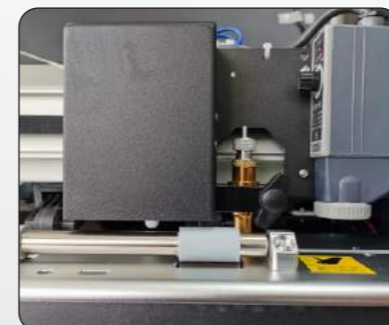

The Sunfung LC34 digital label cutter is a game-changer when it comes to printing large quantities of work in record time. The LC34 can cut materials of up to 340mm x 1500mm in size, automatically feeding 100 sheets or 18mm total thickness into the hopper without human intervention. The digital label cutter has an adjustable downward contact pressure of 800g which allows it to cut a large variety of materials (excluding metal materials) that are not more than 1mm thick at a time. All you need do is set your preferences and your work will be done in record time.

The Sunfung LC34 digital label cutter is most suited for the efficient production of labels and contour-cut stickers for use in product labeling, copy shops, office applications and other business areas. It is also easily maintained and will be a valuable addition to relevant businesses

### MAIN FEATURES:

Model:	SF-LC34
Max sheet size(mm):	350 x 2000
Max cutting surface(mm):	340 x 1500
Max thickness(mm):	1
Downforce(g):	50 - 800
Max cutting speed(mm/s):	800
Hopper capacity:	100 sheets/ 18mm
Display:	2 x 16 high resolution LCD
Driver:	Digital DC, Step motor, Micro-step driver
Mechanical resolution(mm):	0.025
Repetition accuracy(mm):	+/- 0.01
Interfaces:	U disk, USB
Net weight(Kg):	25
Gross weight(Kg):	30
Machine dimensions(mm):	765 x 570 x 365
Package dimensions(mm):	877 x 525 x 400
Power supply:	AC90-240V / 50Hz - 60Hz
Environment:	5°C - 35°C, up to 70% humidity
Options:	WIFI, Network interfaces





## **Sunfung Technology Corporation Ltd**

---

Leading Print Finishing Equipments Supplier