



SUNFUNG

Manufacturer and supplier for paper folder,
paper cutter, card cutter, laminator, creaser
and label cutter from China.

Leading Print Finishing Equipments Supplier

CATALOGUE

SUNFUNG

2022



CATALOGUE

Cutter	4
Laminator	15
Bander	20
Creaser	23
Folder	28



Cutter'

CUTTER

If you are looking to finely cut and trim paper, or other sheets, then our fully-electric guillotine paper cutter may interest you. **The automated operations and functionalities eliminate the need of having manual operators on duty.** Just adjust the digital settings to start cutting the paper in predetermined measurement.



We have

SF – 490E

SF-490E automatic paper cutter offers precision cutting for paper stacks up to 80mm, 490mm width max, **5 cuts per program with 99 programs in total, and electric back gauge control.** It has a **0.3mm cutting accuracy with quiet operations.** **IR safety beam guard. Electric clamp and electric backgauge control, with quiet operations.**

The P series paper cutter handles paper up to 720mm wide, **cutting accuracy is 0.3mm** on paper stacks up to 80mm. The bright LED cutting line shows operators exactly where the blade will cut. Its compact footprint gives you a heavy-duty machine at **half the size of other manufacturer's cutters.**

SF – H52P/H67P/H80P

Heavy duty paper cutter 800mm from SUNFUNG Technology. **300gsm paper full load keep working 24 hours.** They are **the most powerful to precisely cut large stacks of paper stock.** Our SF-H series of **hydraulic and programmable** paper cutter is the perfect cutter for print finishing and on-demand use. **SF-H80P uses 380V three-phase electricity.**

SF – 52P/67P/72P

PAPER CUTTER

SF – 490E

- Accommodates 490mm cutting width
- Easy-to-read LCD display
- Full light beam curtain and dual palm cut buttons for operator safety
- LED illuminated cutting line
- 99 programs with 5 steps each
- Power back gauge, electric, variable speed back gauge line adjustable
- Quiet operation



Max cut width: 490mm(max)

Max cut height: 80mm(max)

Min cut length: 30mm(min)

Display: LCD

Cut precision: 0.3mm

Back gauge control: Electric

Program: 5 cuts x 99 programs

Voltage: 220V ±10% 50Hz

Power: 1.2 kw

Weight: 165kg(G.W.)

Size(mm): 950*780*1225(Machine)



PAPER CUTTER

SF – 52P/67P/72P

- Hydraulic-powered, rugged construction
- 10 inch touch screen
- Beam with CE standard for operator safety
- Double guide back gauge
- The capacity to program up to 100 jobs/16 cuts
- Clamp pressure from 200 to 20,000N adjustable
- PC board with mechanical safety relay
- Aviation aluminum sheet table with hard oxidation treatment

Model:	SF-52P	SF-67P	SF-72P
Max cut width(mm):	520	670	720
Min cut length(mm):	30	30	30
Max cut height(mm):	80	80	80
Cut precision:	0.2mm	0.2mm	0.2mm
Weight(G.W.):	430kg	490kg	540kg
Size(mm):	1250*1010*1390	1400*1010*1390	1450*1010*1390
Back gauge control:	Programmable		
Paper clamp:	Hydraulic + Foot pedal		
Voltage:	220V/50Hz, 110V/60Hz		
Display:	10 inch touch screen		
Safety protection:	Blade lock + CE safety beam guard		



PAPER CUTTER

SF – H52P/H67P/H80P

- Heavy duty design and construction
- Double guide back gauge
- Omron PLC control box
- Easy-to-use 10 inch touch screen
- Industrial level beam guard with CE
- The capacity to program up to 100 jobs/16 cuts
- Clamp pressure from 200 to 20,000N adjustable
- AC servo Motor and Vane pump from Taiwan
- Air table

Model:	SF-H52P	SF-H67P	SF-H80P
Max cut width(mm):	520	670	800
Min cut length(mm):	30	30	30
Max cut height(mm):	80	80	80
Cut precision:	0.2mm	0.2mm	0.2mm
Weight(G.W.):	500kg	620kg	935kg
Size(mm):	1250*1010*1390	1400*1035*1460	1650*1085*1460
Back gauge control:	Programmable		
Paper clamp:	Hydraulic + Foot pedal		
Voltage:	220V	220V	380v
Display:	10 inch touch screen		
Safety protection:	Blade lock + CE safety beam guard		



SF – H80P



SF – H52P/H67P



CARD CUTTER



SUNFUNG introduces print finishing equipment the SF-E series automatic Business Card Cutter. **Get any number of business cards** of predetermined dimension from **a single sheet almost hassle-free**. This automatic friction feed card cutter comes standard with gutter cut **producing 10-up business cards from a A4, A3, SRA3, A3+ size sheet**.

Able to cut coated sheet, laminated sheet, card sheet and other printed material. Equipped with waste bin, **easy to use LCD display screen** and the ability to control the cutting accuracy with a register mark reader. Additional cartridges are available to **produce different card sizes**. This high precision card cutter is built stylish and durable **with long life self-sharpening blades**. This high-performance machine is **simple to operate and requires little maintenance**. Exchangeable cartridges allows you to cut 2" x 3.5" cards.

We have

The **SF-E series** Card Cutter is a high-quality, economical solution **for short-run production** of full-bleed business cards postcards, photos, and more. Its rugged, compact design allows users to cut cards on demand, **up to 144 business cards per minute**.

SF – EA4/EA3

Using an **automatic friction-feed system**, the SF-E series Card Cutter has the ability to cut coated and uncoated paper, laminated sheets, and card stock. Its precision cutting blade is self-sharpening **and accurate up to 0.1mm**. Users can **also choose to enhance accuracy** by using the built-in register mark reader.

With its **user-friendly features and space-saving design**, the SF-E series Card Cutter is an ideal solution **for print shops, small businesses, and schools** that need to produce small batches of cards on demand quickly and easily.

CARD CUTTER

SF – EA4/EA3

- Automatic friction feeding
- Two sheets detection
- Programmable set
- LCD display
- CE safety standard
- Self-sharpening blades
- 1 million sheets cutting

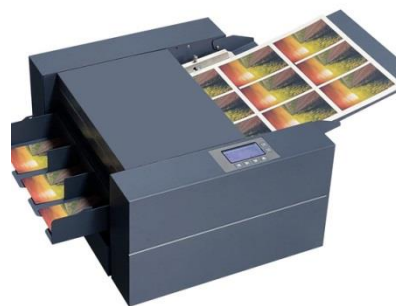

SF – A3



SF – A4

Model:	SF – EA4	SF – EA3
Paper thickness:	180-450g/m ²	180-350g/m ²
Paper feed size:	210*297mm, 8.5"*11"	297*420mm, 11"*17"
Weight(G.W.):	15kg	20kg
Size(mm):	560*390*250mm	720*530*250mm
Card size:	(85, 89, 90, 95, 54, 55) x (1 –600)mm	
Paper type:	Coated paper, Non-coated paper, Laminated paper	
Feeding:	Double friction	
Feeding volume:	12 pcs paper(250 gsm)	
Power:	AC 90-260V, 50/60Hz, 0.5A	
Cutting accuracy:	0.1mm	
Cutting speed:	100 cards/30 sec	



FLATBED CUTTING PLOTTER



The SUNFUNG flatbed cutting plotter **represents the latest in advanced flatbed technology**. Designed with an eye for precision and accuracy, it allows clean and accurate cuts in a wide array of materials. **Perforation cut, Kiss cut, Die cut, Creasing** – everything you need to create production quality products. Included **Tools are Cutter Blade / Pen / Creasing/Etching tool**. Dual head operation allows wide choice of options. The advanced **CCD camera** allows the flatbed to **read registration marks as small as 5mm, reading 4 registration marks can happen as fast as 4 seconds**, which means **production times are maximized**. Connect via **USB** or for longer distances, you can use Ethernet. You can even connect via **U-disk (thumb drives)** for stand-alone operation with no PC attached.

We have

SF – 4056/9060

- **High-resolution camera for accurate detection of registration marks on both colored and transparent materials.**
- **Variable material available like high reflective material, transparent materials, PVC, magnet material, etc.**
- **Sign Master software support Ai 8.0, PDF, all bitmap file format**
- **Perforation cut, Kiss cut, Die-cut, Creasing**
- **50-2000g adjustable down force**
- **Windows OS compatibility**
- **Make packaging boxes, tags, hobbies & crafts, labels, etc.**
- **2 years warranty**

FLATBED CUTTING PLOTTER

SF – 4560/9060

Model:	SF- 4560	SF- 9060
Max cut surface(mm):	600*450	600*900
Weight:	180	200
Max cutting speed:	700mm/s	
Cut function:	Die-cut/Crease/kiss-cut/Perforation	
Film format:	Ai8.0, PDF, all bitmap	
Repetition accuracy(mm):	±0.05mm	
Positioning:	CCD camera	
Interfaces:	U-disk, USB2.0,WIFI	
Voltage:	AC90-240V / 50Hz - 60Hz, 100W/780W(air pump)	
Display:	10 inch touch screen	
Environment:	5-35°C, up to 70% humidity	
Package dimensions(mm):	1050*900*1020	1370*1020*1020

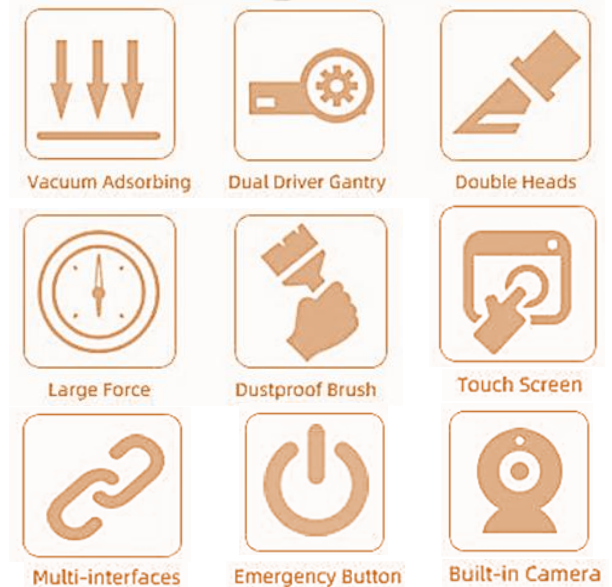

LABEL CUTTER



The SUNFUNG LC34 digital label cutter is a game-changer when it comes to **printing large quantities of work in record time**. The LC34 can cut materials of up to 340mm x 1500mm in size, **automatically** feeding 100 sheets of 18mm total thickness into the hopper **without human intervention**. The digital label cutter has an **adjustable downward contact pressure of 800g** which allows it to cut a large variety of materials (excluding metal materials) that are not more than 1mm thick at a time. All you need do is set your preferences and your work will be done in record time. In addition, the LC34 can be used as a label sheets cutter and a label cutting plotter or sheet to sheet label plotter, all designed to **ensure its optimal performance**. It has a **quiet label cutting** with a **speed of up to 800mm/s** and this is one of the features that sets the LC34 aside from other digital label cutters.

We have

SF – LC34

- **High Precision.** It has an improved label cutting accuracy due to the industrial high precision sensor on the double wheel roller clamp. Thus, it can cut even the smallest fonts in various colors.
- **Speed.** The LC34 digital label cutter can cut 30 pieces of 5cm square image in 50 seconds and 35 pieces of 5cm diameter round image in 63 seconds.
- **Wide application.** It is perfect for printing a wide variety of self-adhesive materials including film, paper, non-woven cloth, and so on.
- **Versatility.** It is easy to use and has a broad application. There are 4 user interfaces which make it easy to transfer your work via Wi-Fi, USB, U Disk or through a LAN Network.

LABEL CUTTER

SF – LC34

The SUNFUNG LC34 digital label cutter is most suited for the efficient production of labels and contour-cut stickers for use in product **labeling**, **copy shops**, **office applications** and **other business areas**. It is also easily maintained and will be a valuable addition to relevant businesses.

Model:	SF – LC34
Max sheet size:	350*2000
Max thickness(mm):	1
Max cutting surface(mm):	340*1500
Downforce:	50-800g
Max cutting speed:	900mm/s
Repetition accuracy(mm):	±0.01mm
Driver:	Digital DC, Step motor, Micro-step driver
Interfaces:	U-disk, USB
Voltage:	AC90-240V / 50Hz - 60Hz
Display:	2 x 16 high resolution LCD
Environment:	5-35°C, up to 70% humidity
Package dimensions(mm):	765*570*365(machine)

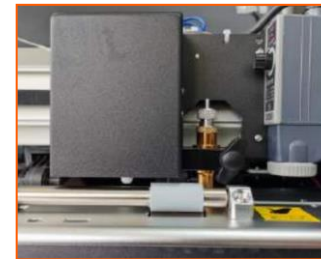



Laminator

LAMINATOR

We at SUNFUNG, offer a wide range of heavy duty laminating machines. Reinforce your fragile papers, posters and vinyl sheets with industrial laminators that **promise superior quality and stimulate production.** Roll laminators from SUNFUNG have **unique anti-curl technology**, in sync with the control panel, ensures that whatever you laminate comes out flat with no curl or uplift.



We have

SF – 390

The electric laminator **390** from SUNFUNG is an **entry-level laminator**, allows the flexibility of **single side OPP roll film lamination** and encapsulation providing an affordable and effective solution to outsourcing. **The semi-automatic feed with a perforation tool makes it easy to feed your work** through the laminator and separations. Truly affordable semi-auto electric laminator for digital printing market.

The **SF-390A** automatic roll laminator is **one of the best single sided thermal laminating machines** available in the market. They're simple to use, easy to maintain, quick, and reliable. Laminator Manufacturer SUNFUNG introduced **Automatic feeding & Automatic separation** help release operators hands, **increase their efficiency and save their time.**

SF – 390A

SF – 540A

Heavy duty from SUNFUNG is a hot laminator that allows the flexibility of **single side OPP roll film lamination.** It is built for continuous use on an everyday basis, and constructed **using parts of the highest quality only.** This is **the best value single-sided laminator on the market**, is simple to use, easy to maintain, quick and reliable. The automatic feed with **auto-overlap makes it easy to feed your work** through the laminator and the separator ensures it's ready for the guillotine the moment it's been laminated.

SEMI-AUTO LAMINATOR

SF – 390

- Semi-auto feeding with overlap feature
- Pneumatic auto separation
- The anti-curl bar allows thin film laminates to be flat
- Mirror chrome heating roller
- Thermal or Cold laminating
- Touch screen display system
- Digital foiling
- 2 rolls film installation
- Adjustable electric hydraulic pressure system

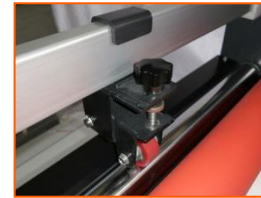

Roll film width: $\leq 390\text{mm}$

Laminating material: BOPP film

Roll film thickness: 25-32 mic

Paper thickness: 157-350 g/m²

Speed: 0.5-15m/min

Temperature: 80-130°C

Heating mode: Oil heating

Pressure control: Hydraulic

Core: 1 inch/ 3 inch

Display: Touch screen

Anti-Curl: Yes

Overlap accuracy: $\pm 1.5\text{mm}$

Voltage: 220-240V(AC), 50/60Hz

Power: 3.5kw

Weight: 285kg(G.W.)

Size(mm): 1730*760*1420(Machine), 760*830*1350(Package)

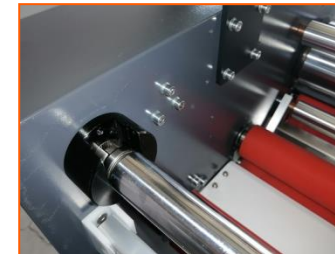

AUTO LAMINATOR

SF – 390A

10-15 meters per min can satisfy most of on demand digital applications. Foil rewinder allow customers to **make foiling on digital printings**. Heavy duty hydraulic laminator guarantee daily **workings in long-term**.



Roll film width: 390*520mm

Laminating material: BOPP film

Roll film thickness: 20-45 mic

Paper thickness: 130-400 g/m²

Speed: 0-15m/min

Temperature: 80-130°C

Feeding mode: Dual air suction

Pressure control: Hydraulic

Core: 3 inch

Display: 7 inch touch screen

Auto feeding: Yes

Foil feature: Yes

Voltage: 220V/50Hz, 240V/60Hz

Power: 3.2kw(total)

Weight: 380kg(G.W.)

Size(mm): 1730*800*1480(Machine)

AUTO LAMINATOR

SF – 540A

Heavy duty from SUNFUNG is a hot laminator that allows the flexibility of **single side OPP roll film lamination**. It is built for continuous use on an everyday basis, and constructed using **parts of the highest quality only**. This is **the best value single-sided laminator on the market**, is simple to use, easy to maintain, quick and reliable. The **automatic feed with auto-overlap makes it easy to feed your work** through the laminator and the separator ensures it's ready for the guillotine the moment it's been laminated.



Roll film width: 540*760mm

Laminating material: BOPP film

Roll film thickness: 17-38 mic

Paper thickness: 130-450 g/m²

Speed: 20m/min

Temperature: 20-140°C

Feeding mode: Dual air suction

Pressure control: Hydraulic

Core: 3 inch

Display: 7 inch touch screen

Auto feeding: Yes

Foil feature: Yes

Voltage: 220V/50Hz, 240V/60Hz

Power: 6.5kw(total)

Weight: 510kg(G.W.)

Size(mm): 1500*1150*1350(Machine)





Bander |

PAPER BANDER



The **SF-42B** Paper Bander wraps a strip of craft paper or film around the bundle, **providing you with the same security but at a lower cost than a box**. The SF-42B can be placed near your finishing machine for an efficient finishing and packaging operation. **Operation is simple** - just take the finished pieces and place them into the SF-42B, which will automatically detect the bundle and wrap it. This keeps the materials orderly and allows for easy and accurate distribution. **Either craft paper or film can be used** in the SF-42B and will keep your materials just as secure as putting them in a box or bag.

If you need a little extra capacity in your paper banding operations, you may want to consider using the SF-42BS automated paper banding machines. This paper banding machines use large banding tape rolls (paper or plastic) to quickly bundle material together. **Max tape reel outer diameter is 340mm (13.3")**, which sit to below of the machine. This machine is extremely easy to use and **can bundle stacks of brochures, boxes, booklets, pamphlets and much more**. Simply insert the material you need to band together and then press a button, press a foot pedal or let the photo sensor automatically cycle the machine. **It is perfect for daily use and take up little space**.

We have

SF – 42B/42BS

- **High capacity banding machine**
- **Bundles finished pieces such as business cards, postcards, and brochures**
- **Tabletop or Vertical design**
- **Manual or automatic operation**
- **Craft paper and film available**
- **Bundle strength adjustable**
- **Cost-effective method of packaging printed material**

PAPER BANDER

SF – 42B/42BS



Model:	SF- 42B	SF- 42BS
Banding speed:	26 bundles/min	26 bundles/min
Max banding size:	410*200mm(W*H)	410*200mm(W*H)
Min banding size:	40*10mm(W*H)	40*10mm(W*H)
Tape width:	30mm / 40mm / 50mm / 20mm / 25mm	
Tape types:	Craft paper or Film	Craft paper or Film
Tape reel core diameter:	40mm	76mm
Tape reel outer diameter:	170mm	340mm
Dimension:	560*490*300mm	560*1100*300mm
Voltage:	110V/220V, 50-60Hz, 200w	
Weight:	33kg	63kg





Creaser'

CREASER

The SUNFUNG SF - Series offer a full product line of crease/perforate and crease/fold solutions ranging from entry level machines that provide professional results at a fraction of the cost to high volume, fully automated systems.



We have

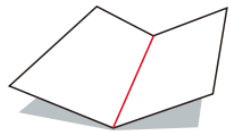

-Single Crease-

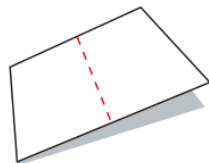

-Perf & Crease-

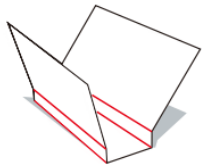

-Spine & Hinge-

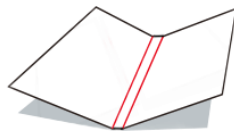

- Flatback -

SF – 10/20E

The SF-10/ SF-20E is versatile vacuum pile fed **automatic creaser with multiple finishing options**; cross perforating (with the capability to do partial perforate), **choice of 5 creasing widths, and an array of rotary tools**; perforating, scoring, and kiss-cutting. Equipped with interchangeable creasing/perforating dies, the SF-20E/ SF-10 can quickly switch over from creasing to prevent toner cracking to perforating for tear off pieces. The SF-20E **can be placed on an optional stand or used as a tabletop machine with removable trays to minimize the footprint.**

SF – 30

7 inch touch screen guarantee user with good working experiences with this machine. **Whole set slide tool guarantee the accuracy** and long time use. Also the SF-30 **added the linear tool**, so that customer can make cross line creasing or perforations in one pass. **Paper length for 900mm** feeding and collection is OK. **Creasing speed been updated to 8200 pages per hour.**

NON-AUTO CREASER

SF - 10

The product developed based on our technological superiority and production capacity. The processing position is digital control with **creasing and perforating two functions in one**. The working width is 340mm, paper thickness 100-350g(Max). Paper working length 900mm(Max). **32 creasing times on one paper**. Hope this machine will makes your work perfect and help you a lot.



Paper size: 50*90mm(Min), 340*900mm(Max)

Paper thickness: 100-350 g/m²(creasing), 100-200 g/m²(perforating)

Paper type: Coated paper, Laminated paper, Varnish paper etc.

Working accuracy: ± 0.2 mm

Working speed: 3000 pages/h (one crease on each A4 paper)

Creasing times in each paper: 0-32 times

Voltage: 220V/50Hz, 110V/60Hz Power: 150w

Weight: 42kg(N.W.), 48kg(G.W.)

Size(mm): 1190*505*405(Machine), 610*600*500(Package)



AUTO CREASER

SF – 20E

The SF-20E auto creaser is a versatile automatic creaser with **multiple finishing options** like **perforating, scoring, creasing**. Equipped with a 90mm vacuum pile feeder, an easy to use **LCD screen and keyboard**, skew compensation, and sheet size up to 320 x 660mm. With a **maximum of 32 crease/perforate positions per sheet, 30 job memory, and speeds up to 3,000 pages/h**, the SF-20E auto creaser is a capable and affordable finishing option. **Choose this and free your hands.**



Paper size: 150*210mm(Min), 320*660mm(Max)

Paper thickness: 100-350 g/m²(creasing), 100-200 g/m²(perforating)

Paper type: Coated paper, Laminated paper, Varnish paper etc.

Working accuracy: ± 0.2 mm

Working speed: 3000 pages/h (one crease on each A4 paper)

Creasing times in each paper: 0-32 times

Voltage: 220V/50Hz, 110V/60Hz

Power: 200w

Weight: 63kg(N.W.), 70kg(G.W.)

Size(mm): 1640*560*400(Machine), 760*680*530(Package)

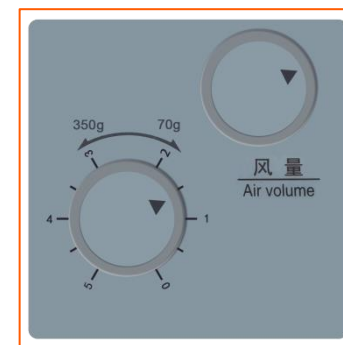

AUTO CREASER

SF – 30

7 inch touch screen guarantee user with good working experiences with this machine. **Whole set slide tool** guarantee the accuracy and long time use. Also the SF-30 **added the linear tool**, so that customer can make cross line creasing or perforations in one pass. **Paper length for 900mm** feeding and collection is OK. **Creasing speed been updated to 8200 pages per hour.**



7 inch
touch screen



Slitter
Work efficiently



100mm thickness
Feeding volume

Paper size: 150*140mm(Min), 330*900mm(Max)

Paper thickness: 100-350 g/m²(creasing), 100-200 g/m²(perforating)

Paper type: Coated paper, Laminated paper, Varnish paper etc.

Working accuracy: ± 0.3 mm

Working speed: 8200 pages/h (one crease on each A4 paper)

Creasing times in each paper: 0-32 times

Voltage: 220V/50Hz, 110V/60Hz

Power: 600w

Weight: 124kg(N.W.), 130kg(G.W.)

Size(mm): 2040*560*1140(Machine), 760*680*530(Package)



Folder

FOLDER

Save your precious time and effort in folding large sheets **without any crease or pesky corrugation** with our high-performance paper folders. Embrace lean manufacturing with our advanced paper folding machines that boast of user-friendly features and flexible functionalities to scale your business to the next level.



We have

SF – 12M

This compact folder processes **A4 paper** at speeds **up to 7,400 sheets per hour**, and is pre-marked for **four popular folds: C, Z, Half, and Double Parallel**. Clearly marked fold settings and out-of-the-box operation make this folder ideal **for churches, schools and small offices**

SF – 14M

For the Pharmaceutical Industry, the SF-14M paper folding machine is a multi-purpose functioning folding machine for the pharmaceutical factory. Its **durable construction, simple operation, excellent design and attractive appearance** makes it a **unique machine in the world for the pharmaceutical industry**.

SF – 32M

SF-32M paper Folder is a solid and durable machine, and an extremely **economical solution to fold large paper volumes**. The SF-32M can process a large variety of applications and is easy to operate. It **works fast and accurately** and can be used in any offices and mailrooms.

SF – 34M

For the Pharmaceutical Industry **SF-34M** paper folding machine is a **multi-purpose functioning folding machine for the pharmaceutical factory**. Its durable construction, simple operation, excellent design and attractive appearance make it **a unique machine in the world for the pharmaceutical industry**.

PAPER FOLDER

SF – 12M

- LCD control panel with 3-digit resettable counter
- Auto Batch for processing sets of documents
- Output conveyor with easily-adjustable stacker wheels for neat sequential stacking of folded pieces

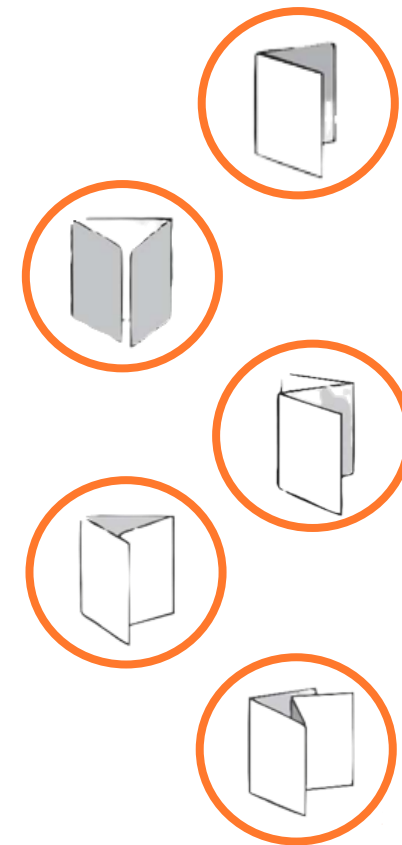
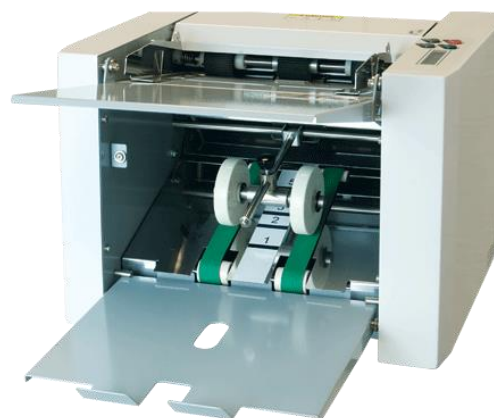

Folding speed: 7000 sheets/h

Paper size: B6-A4

Paper weight: 35-120 g/m²

Hopper capacity: 300 sheets, 64 g/m²

Power supply: 220V, 50Hz/ 110V, 60Hz

Size: W 670* D 360* H 450 mm

Weight: 18kg

This compact folder processes A4 paper at speeds up to 7,400 sheets per hour, and is pre-marked for four popular folds: **C, Z, Half, and Double Parallel.**

FOLDING INSTRUCTION	A4	
	UPPER PLATE	LOWER PLATE

PAPER FOLDER

SF – 14M



- The SF-14M A4 origami machine can handle paper up to A4
- Additional fold adjustments can be made using the fine adjustment knobs at the end of each fold plate for precise folds
- The only desktop medical paper folder on the market
- It holds over 12 different kinds of fold types based on the 4 fold plates.

Folding speed: 7000 sheets/h

Paper size: B6-A4

Paper weight: 35-120 g/m²

Hopper capacity: 300 sheets, 64 g/m²

Power supply: 220V, 50Hz/ 110V, 60Hz

Size: W 480* D 520* H 470 mm

Weight: 25kg

The **SF-14M** paper folding machine handles the paper with a maximum speed of 7200 sheets/h. The capacity of the automatic feed station is up to 500 sheets. The job counter informs about the number of folded sheets. **For the Pharmaceutical Industry, the SF-14M paper folding machine is a multi-purpose functioning folding machine for the pharmaceutical factory.** Its durable construction, simple operation, excellent design and attractive appearance makes it a **unique machine in the world for the pharmaceutical industry.**

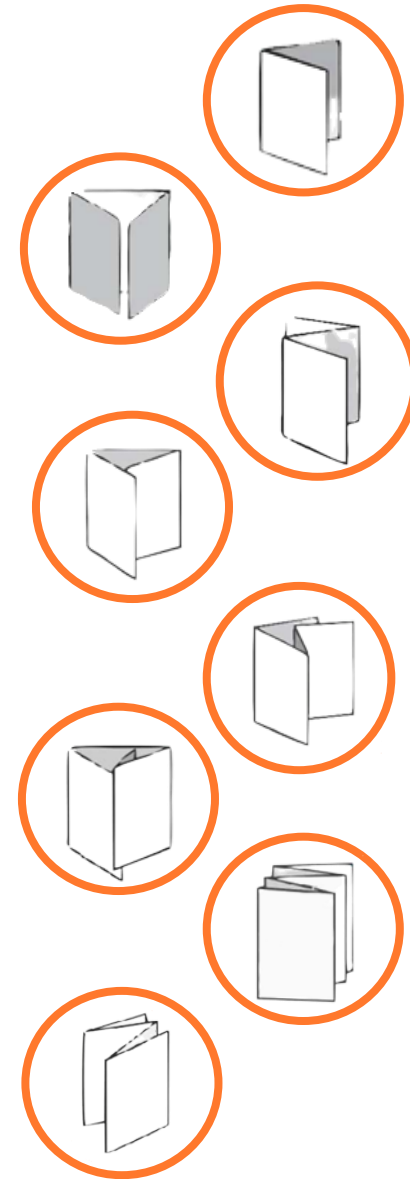

PAPER FOLDER

SF – 32M

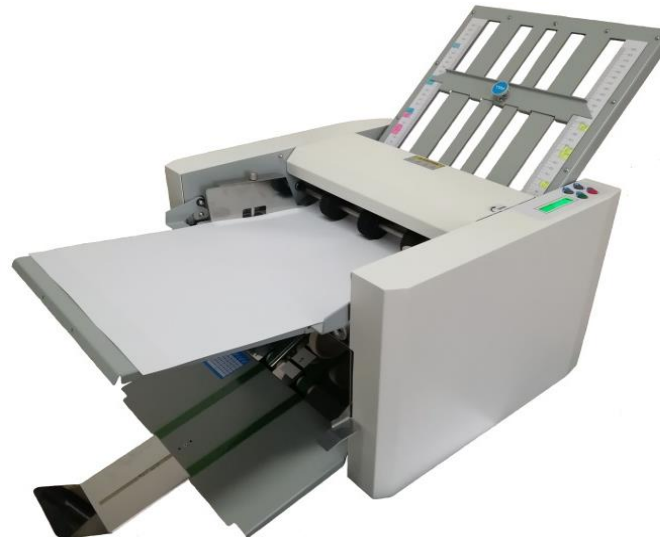

- Maximum for A3 paper, feeding pressure adjustable for various kinds of papers in the market
- Six popular fold types available, including Letter fold, Half fold, Double Parallel, Accordion fold, Gate fold and Fold-out
- It also has creasing function, which satisfy different customers' demands

Folding speed: 7000 sheets/h

Paper size: B6-A3

Paper weight: 50-200 g/m²

Hopper capacity: 500 sheets, 64 g/m²

Power supply: 220V, 50Hz/ 110V, 60Hz

Size: W 890* D 480* H 520 mm

Weight: 35kg

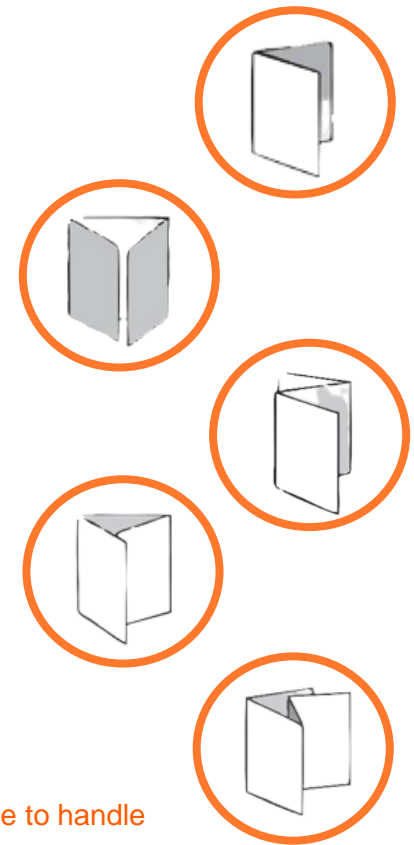

The **SF-32M** Desktop Paper Folder is able to handle sheets up to A3. The adjustment of the folding plates is done in no time, as both folding plates have a self-explaining scale for **6 different fold types, including cross folding**. Additionally, each plate is equipped with a quick and fine-tune adjustment to always achieve perfect folding results, whether the application is a **letter, flyer, brochure or billing statement**.

PAPER FOLDER

SF – 34M



- Maximum for A3 paper, feeding pressure adjustable for various kinds of papers in the market
- Six popular fold types available, including Letter fold, Half fold, Double Parallel, Accordion fold, Gate fold and Fold-out
- It also has creasing function, which satisfy different customers' demands

Folding speed: 7000 sheets/h

Paper size: B6-A3

Paper weight: 50-200 g/m²

Hopper capacity: 500 sheets, 64 g/m²

Power supply: 220V, 50Hz/ 110V, 60Hz

Size: W 1240* D 550* H 464 mm

Weight: 48kg

SUNFUNG paper folding machine handles paper with a maximum **speed of 7200 sheets/h**. The capacity of the automatic feed station is up to 500 sheets. The job counter informs about the number of folded sheets.

Paper folding machine SF-34M A3 is able to handle sheets up to A3.

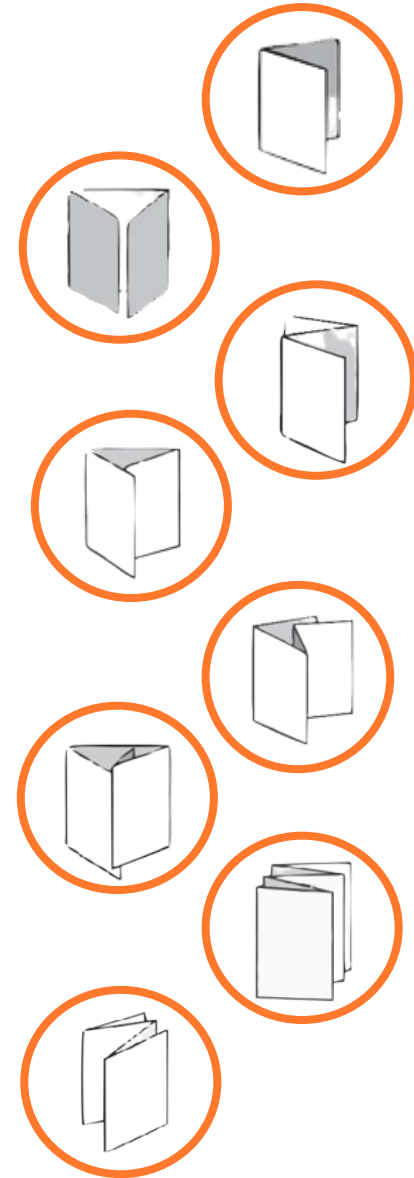



2022

TO BE CONTINUED





SUNFUNG

Please refer to the actual product, and the final interpretation right belongs to our company.

Web: sunfung-tech.com

Add: No.259 Wensan Road, Xihu District, Hangzhou

Phone: 0086-57185175095

Email: info@sunfung-tech.com